

DISTANCE BETWEEN EXPANSION JOINTS

TRENCH WIDTH (12" AND UNDER)

TRENCH WIDTH (OVER 12")

PREFERRED	ACCEPTABLE
4' = 1.22 M	8' = 2.44 M
12' = 3.66 M	16' = 4.88 M
20' = 6.10 M	24' = 7.32 M
28' = 8.53 M	32' = 9.75 M
36' = 10.97 M	40' = 12.19 M
44' = 13.41 M	48' = 14.63 M

PREFERRED	ACCEPTABLE
8' = 2.44 M	12' = 3.66 M
16' = 4.88 M	20' = 6.10 M
24' = 7.32 M	28' = 8.53 M
32' = 9.75 M	36' = 10.97 M
40' = 12.19 M	44' = 13.41 M
48' = 14.63 M	52' = 15.85 M

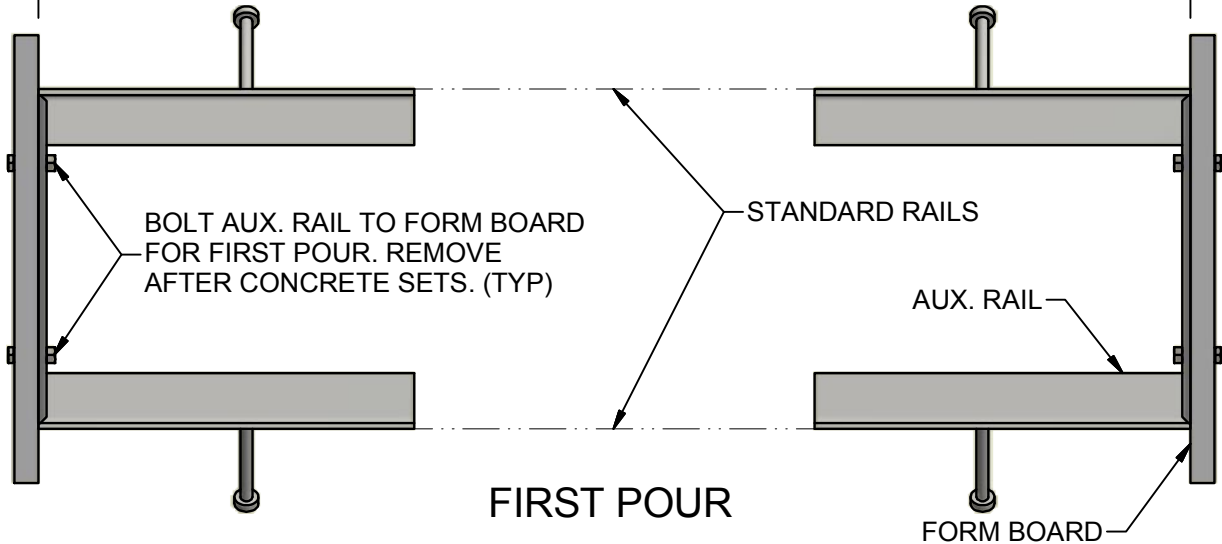

FIRST POUR

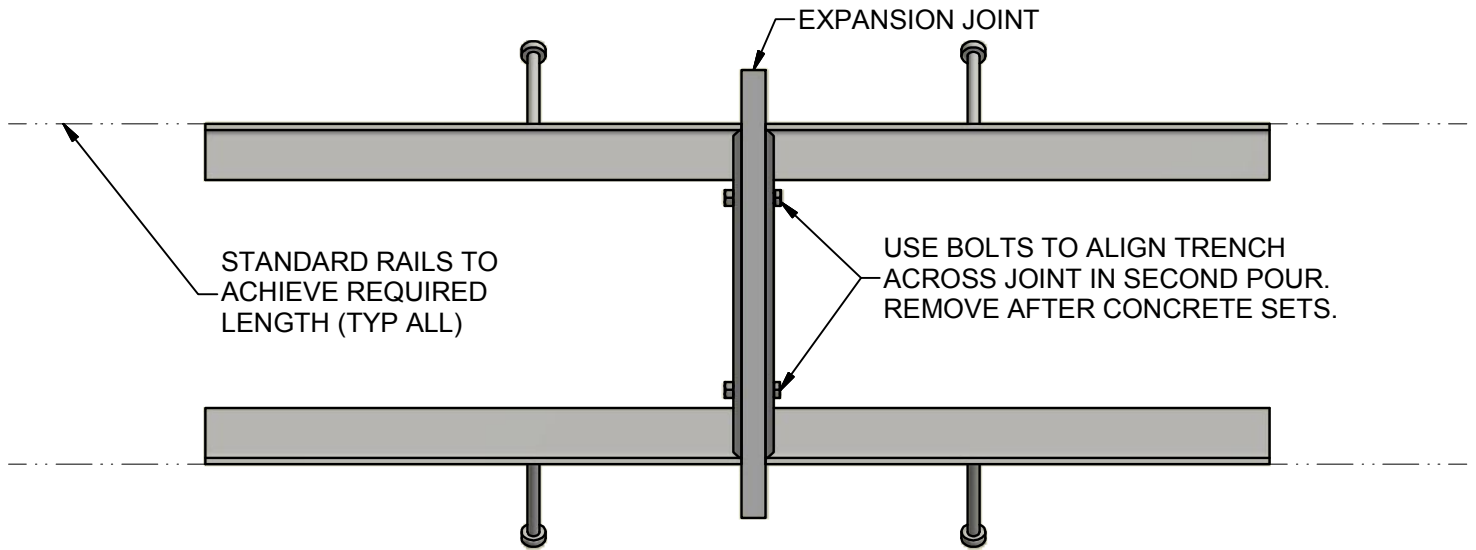

SECOND POUR

ABT, INC.

P.O. BOX 837 / 259 MURDOCK ROAD
TROUTMAN, NC 28166
(704) 528-9806 (800) 438-6057
www.abtdrains.com

INSTALLATION DRAWING © 2015 ABT, Inc.

**TRENCH FORMER DETAIL
TOGGLE LOCK AUXILLARY RAIL - EXPANSION JOINT**

FILE: **DET-TL-EXP-00**

PART: **DET-TL-EXP**

Proprietary rights of ABT, Inc. are included in the information disclosed herein. The recipient, by accepting this document, agrees that neither this document nor the information disclosed herein nor any part thereof shall be copied, reproduced or transferred to others for manufacturing or for any other purpose except as specifically authorized in writing by ABT, Inc.

DISCLAIMER: The customer and the customer's architects, engineers, consultants and other professionals are completely responsible for the selection, installation, and maintenance of any product purchased from ABT, and EXCEPT AS EXPRESSLY PROVIDED IN ABT'S STANDARD WARRANTIES, ABT MAKES NO WARRANTY, EXPRESS OR IMPLIED, AS TO THE SUITABILITY, DESIGN, MERCHANTABILITY, OR FITNESS OF THE PRODUCT FOR THE CUSTOMER'S APPLICATION. Copies of ABT's standard warranties are available upon request.