



P.O. BOX 837, 259 WILKINSON ROAD
TROUTMAN, NC 28166
(704) 528-9806

FILE: S-1640FF24-6HA-02

PART: 1640FF24-6H

SPECIFICATION DRAWING © 2004 ABT, Inc.
FIRST FLUSH™ INLINE DEBRIS TRAP & FILTRATION
2 FT X 2.5 FT X 6 FT UNIT ASSEMBLY

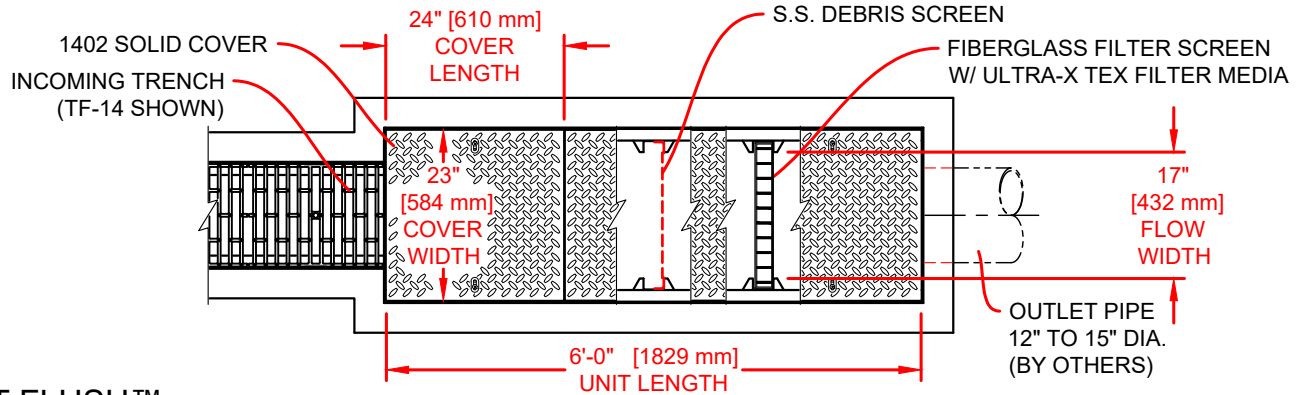

FIRST FLUSH™

INLINE DEBRIS TRAP & FILTRATION
2 FT x 2.5 FT x 6 FT UNIT INCLUDES:

- 1 - EPS FORM
- 1 - S.S. DEBRIS SCREEN
- 1 - FRP SCREEN W/ FILTER MEDIA
- 3 - SOLID COVERS
- 2 - SIDE RAILS
- 2 - END RAILS

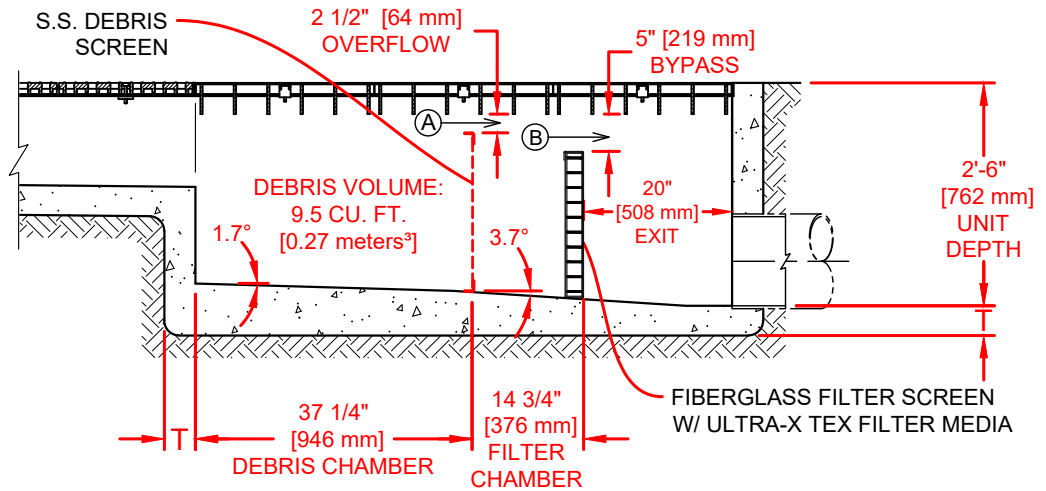

CROSS SECTIONAL VIEW

BYPASS FLOW AREA

Ⓐ →	42.5 in ² [0.027 m ²]
Ⓑ →	85.0 in ² [0.055 m ²]



MONOLITHIC POUR NOTE:
DO NOT USE TRENCH OR UNIT
AS AN EXPANSION JOINT

**T = STRUCTURAL ENGINEER'S SPECIFICATION,
OR FLOOR SLAB THICKNESS, OR 4" MIN. [100mm]
(WHICHEVER IS GREATER)**

Proprietary rights of ABT, Inc. are included in the information disclosed herein. The recipient, by accepting this document, agrees that neither this document nor the information disclosed herein nor any part thereof shall be copied, reproduced or transferred to others for manufacturing or for any other purpose except as specifically authorized in writing by ABT, Inc.

DISCLAIMER: The customer and the customer's architects, engineers, consultants and other professionals are completely responsible for the selection, installation, and maintenance of any product purchased from ABT, and EXCEPT AS EXPRESSLY PROVIDED IN ABT'S STANDARD WARRANTIES, ABT MAKES NO WARRANTY, EXPRESS OR IMPLIED, AS TO THE SUITABILITY, DESIGN, MERCHANTABILITY, OR FITNESS OF THE PRODUCT FOR CUSTOMERS APPLICATION. Copies of ABT's standard warranties are available upon request.