

VectorDrain®/XT

LIGHT DUTY TRENCH SYSTEM



VECTORDRAIN



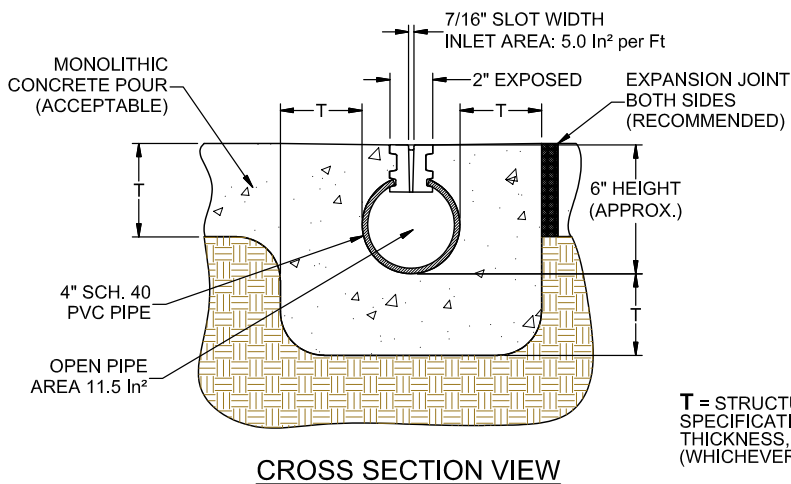
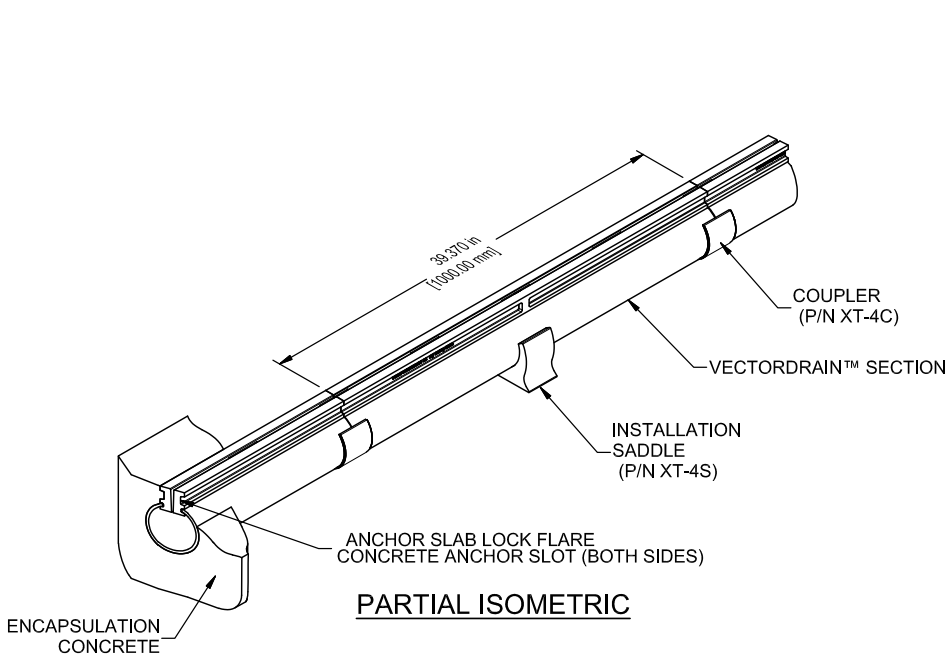

T = STRUCTURAL ENGINEER'S
SPECIFICATION, FLOOR SLAB
THICKNESS, OR 4" [100 mm]
(WHICHEVER IS GREATER)

Visit www.abtdrains.com

ABT designs and manufactures some of the most extensive, reliable, and versatile lines of channel drains, grates, and water management solutions in the industry. If you're an engineer or designer and need performance-based specifications and details for your project, we can help. Visit www.abtdrains.com for details on all our products.



ABT,® Inc.

PO Box 837
259 Murdock Road
Troutman, NC 28166
www.abtdrains.com
Toll-free: 800.438.6057
Phone: 704.528.9806

DISCLAIMER: The customer and the customer's architects, engineers, consultants and other professionals are completely responsible for the selection, installation, and maintenance of any product purchased from ABT, and EXCEPT AS EXPRESSLY PROVIDED IN ABT'S STANDARD WARRANTIES, ABT MAKES NO WARRANTY, EXPRESS OR IMPLIED, AS TO THE SUITABILITY, DESIGN, MERCHANTABILITY, OR FITNESS OF THE PRODUCT FOR CUSTOMER'S APPLICATION. Copies of ABT's standard warranties are available upon request.

11/5/2025