

NOTES:

1. INSTALL ANGLE ASSEMBLIES AS OFTEN AS REQUIRED TO PREVENT TRENCH RAILS FROM DEVIATING BEYOND DESIRED AMOUNT FROM TRUE RADIUS.
2. FILL ANY GAP AT END OF FORMER WITH FOAM-IN-PLACE FOAM OR COVER GAP WITH TAPE PRIOR TO FORMER RELEASE APPLICATION.
3. CALCULATE GAP PER ASSEMBLY IS AS FOLLOWS:

$$\text{GAP (INCH)} = \frac{\text{SPACING BETWEEN ANGLE ASSEMBLIES (INCH)} \times \text{RAIL SPACING (INCH)}}{\text{CURVE RADIUS (INCH)}}$$

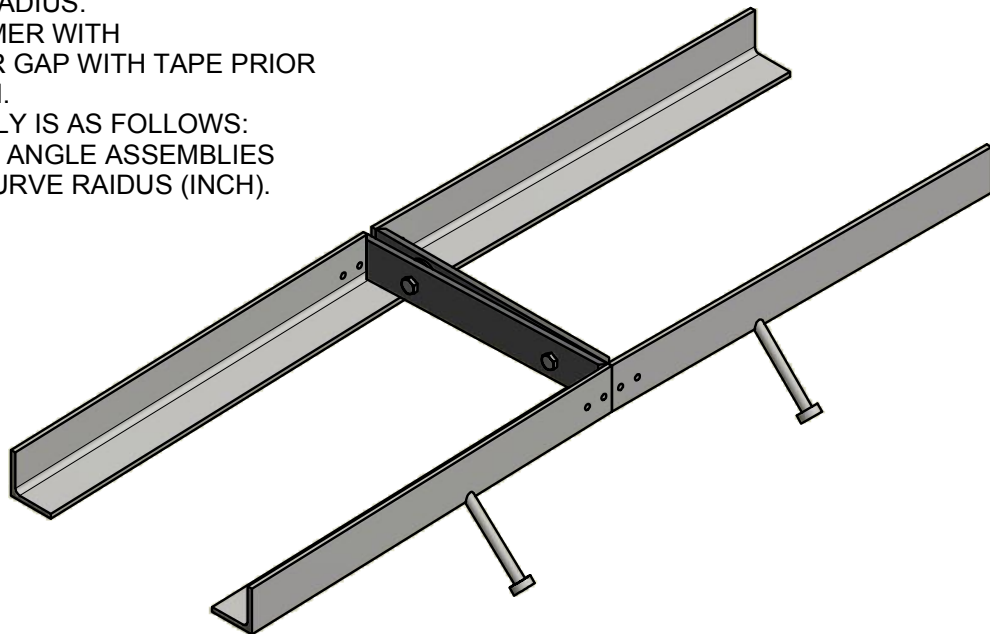

ANGLE ASSEMBLY

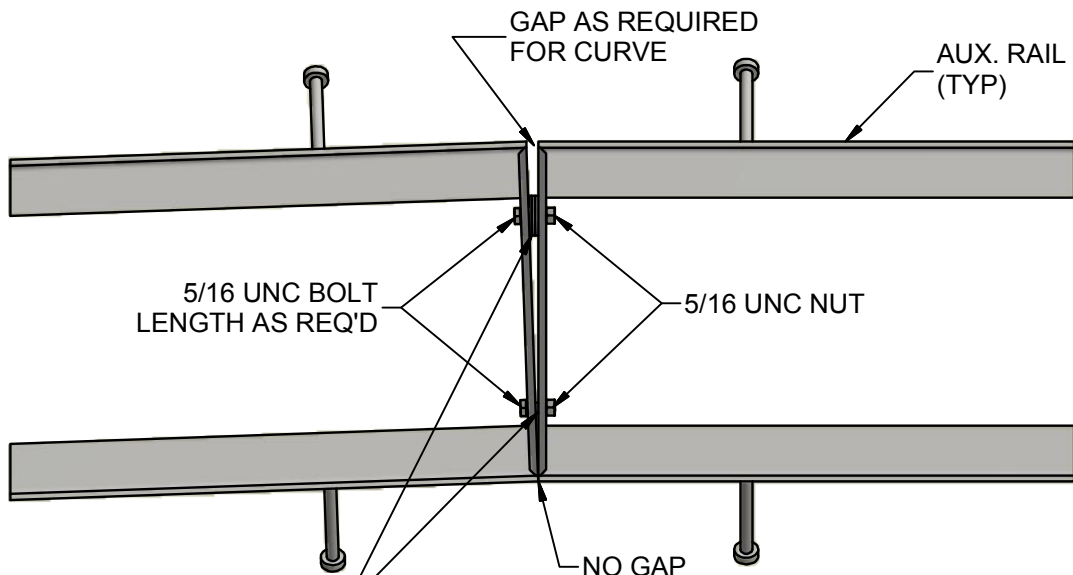

TOP VIEW



P.O. BOX 837 / 259 MURDOCK ROAD
 TROUTMAN, NC 28166
 (704) 528-9806 (800) 438-6057
 www.abtdrains.com

INSTALLATION DRAWING © 2015 ABT, Inc.

**TRENCH FORMER DETAIL
 TOGGLE LOCK AUXILLARY RAIL - SWEEP**

FILE: **DET-TL-SWEEP-00**

PART: **DET-TL-SWEEP**

Proprietary rights of ABT, Inc. are included in the information disclosed herein. The recipient, by accepting this document, agrees that neither this document nor the information disclosed herein nor any part thereof shall be copied, reproduced or transferred to others for manufacturing or for any other purpose except as specifically authorized in writing by ABT, Inc.

DISCLAIMER: The customer and the customer's architects, engineers, consultants and other professionals are completely responsible for the selection, installation, and maintenance of any product purchased from ABT, and EXCEPT AS EXPRESSLY PROVIDED IN ABT'S STANDARD WARRANTIES, ABT MAKES NO WARRANTY, EXPRESS OR IMPLIED, AS TO THE SUITABILITY, DESIGN, MERCHANTABILITY, OR FITNESS OF THE PRODUCT FOR THE CUSTOMER'S APPLICATION. Copies of ABT's standard warranties are available upon request.